



MATRIX
Advanced Scan Technology



MD-600i
Elite Metal Detector
60 Zones Super Detector





MD-600i

Data sheet

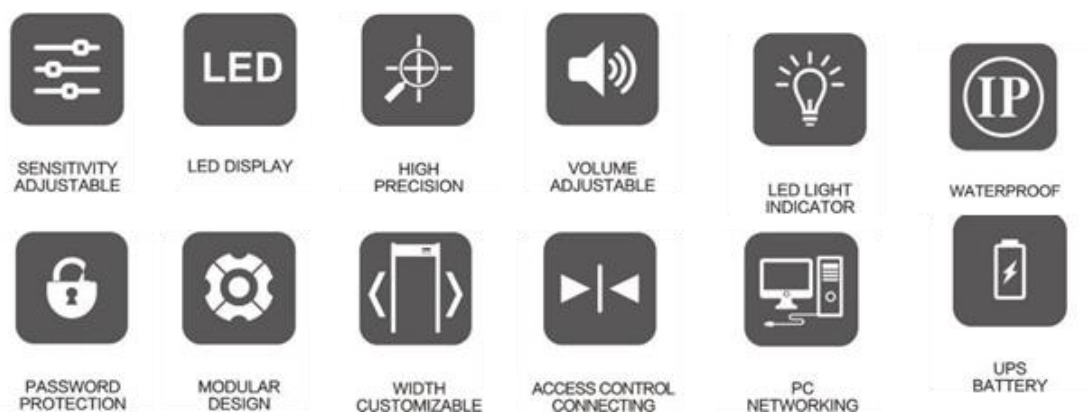

Product Features:

- Function of displaying environmental monitoring data
- High performance, high sensitivity and high stability
- Optional networking function, multiple devices can be managed through one PC
- Wide and large design, more stable, suitable for crowded places
- Comply with EMC electromagnetic radiation standards and adopt weak magnetic field technology, harmless to pacemaker wearers, pregnant women, floppy disks, film and video tapes

Interface Display:

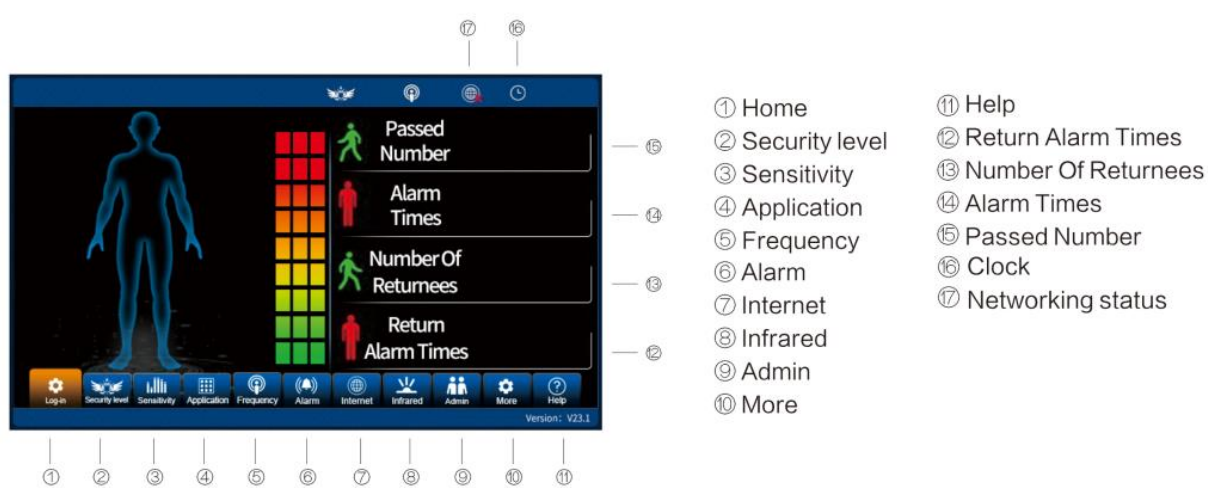

Safety Standards:

- **Conform to Electricity EN60950 Safety Standard**
- **Conform to Radiation EN50081-1 Standard**
- **Conform to Anti-interference EN50082-1 Standard**





MD-600i

Data sheet

Technical Details:	
Detection Zones	60 zones plus
Pass Count	0-999999
Alarm Count	0-999999
Return Pass Count	0-999999
Return Alarm Count	0-999999
Metal Detection Accuracy Range	One-dollar coin
User Interface	7inch LCD touch screen
Password Protection Function	8-digit password protection
Metal Position Indicator	Intelligent zoning indication
Operating Frequency	1-100
Security Level	1-100
Sensitivity Level	0-255
Alarm Volume	0-20
Alarm Sound	1-16
Screen Brightness	10-100
Screen Sleep Time(minute)	1-60
Scene Setting	72 preset scenes
Infrared Start-Stop Setting	Start the former group Start the latter group Start both groups Close both groups
Time Setting	Yes
LED Alarm Bars	Front 2 groups
Simultaneous detection and alarm in multiple zones	2 Detection zones simultaneously alarm
IP Grade	IP 54

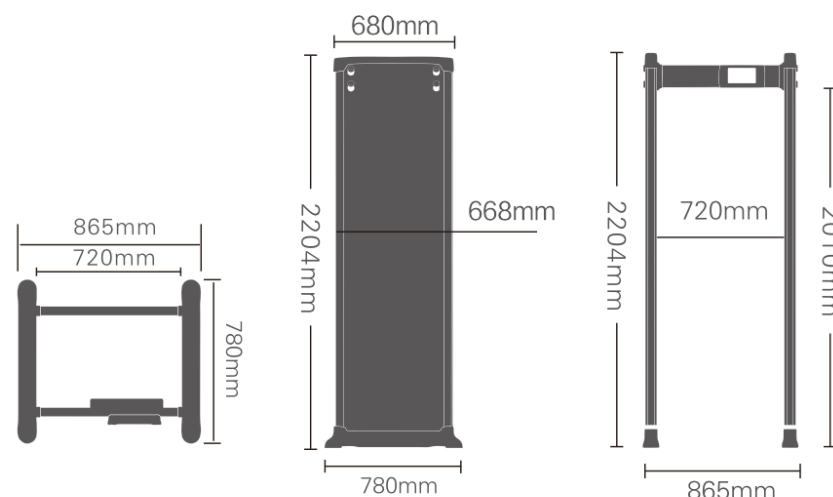

Overall Exterior Size	2204*865*780mm
Passageway Interior Size	2010*720*780mm
Operating Voltage	AC100V~240V 50 / 60Hz
Power	12W
Operating Temperatures	-20°C~65°C
Installation Environment	Width 100cm* Length 200cm (minimum range without metal)

Additional Options:	
<input type="checkbox"/>	Turnstile Connection
<input type="checkbox"/>	Networking Interfaces for Multiple Units
<input type="checkbox"/>	Back up Battery : 4/8/16 Hours
<input type="checkbox"/>	Front and Rear Panel Alarm LED Lights
<input type="checkbox"/>	Secondary Development Port/Upgrade Port

Product Packing Details	
Package Size:	L2290xW1080xH220 mm
Volume:	0.55m ³
Net weight:	58kgs
Gross weight:	65kgs

• Anti-interference Reference Standard



Keep ≥80cm from the X-Ray machine Keep ≥50cm between two units Keep ≥10cm from the wall

Note: The above distances are for reference only, and the actual distances shall be subject to the performance accuracy of on-site debugging; the higher the sensitivity, the greater the distance interval, and the lower the sensitivity, the smaller the distance interval.

• Detection Zones

